

2025

SILO PARA CEMENTO

BR 300

Horizontal

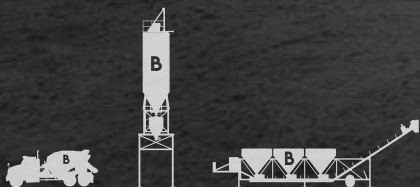

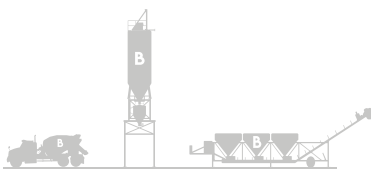

BRAHER MIXERS DE MÉXICO

BR 300

SILO PARA CEMENTO



www.braher.com.mx

Silo Horizontal / BR 300



Materia prima de **calidad**



Seguridad para el operador



Manejo intuitivo



Filtro colector **desmontable**



 30 toneladas

 Horizontal

Equipo **compacto** capaz de responder a trabajos pesados. Ideal para concreteras pequeñas o para **producción** en obra.

- Unidad móvil de **fácil traslado**.
- Tirón tipo dona de 21 toneladas.
- Tolva fabricada en calibre 10.
- **Motor** de 10 Hp.
- **Altura de descarga ajustable**, sistema manual.
- Sistema de **pesaje preciso y confiable**; Cajas sumas, display, botonera con arnés de 20 mts incluido.
- **AHORA** con un **vibrador de 1 Hp** para limpieza y mejor fluidez de descarga.
- Filtro colector de polvos **desmontable** para traslado.
- Estructura interna de PTR **para refuerzo**.
- Válvula de emergencia para evitar accidentes.
- Catarinas y cadenas de **alta resistencia**.
- Poleas fabricadas en acero para su **mayor duración**.
- 4 patines de nivelación.
- Sistema de **apertura de compuertas neumático**, con sensor de apertura.
- **AHORA** con **compuertas selladas** en gusano helicoidal para limpieza y mantenimiento.
- Voltaje de **alimentación a 220v** (opcional 440 v requiere notificar).
- Luces de traslado reglamentarias.

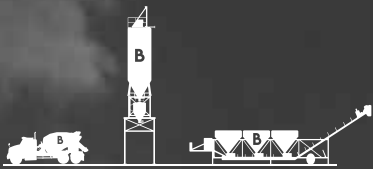

BRAHER MIXERS DE MÉXICO

BR 300

SILO PARA CEMENTO



www.braher.com.mx

Reducción de costos



Mitigación de riesgos



Optimización de tiempos



Proceso agilizado



INSTALACIÓN Y PUESTA EN MARCHA

Silos y plantas dosificadoras BRAHER

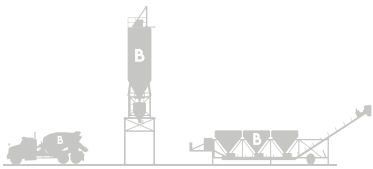

Posición de traslado con filtro colector desmontado.

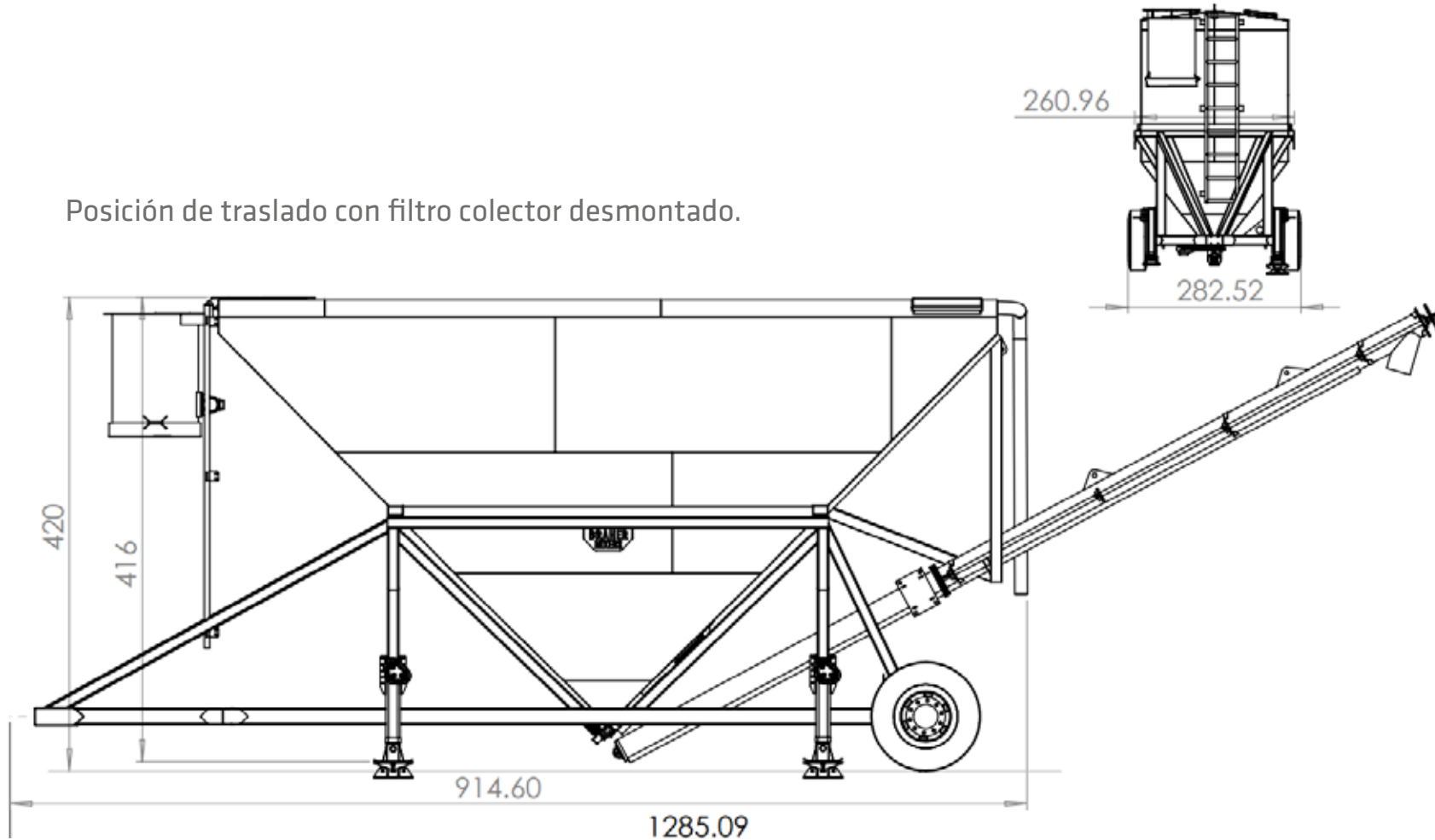

MEDIDAS | SILO BR 300

*Dimensiones expresadas en centímetros. Consulta medidas específicas con un agente de ventas.

Síguenos:



Braher Mixers De México



 391 917 2040

 braher.com.mx